

*Uij dussen*

*Jeep 151 A1  
zenith*

TM 9-2320-218-34-1

4-7. Carburetor Overhaul (Cont'd)

| STEP NO. | LOCATION | ITEM      | ACTION  | REMARKS  |
|----------|----------|-----------|---|--|
| 57.      |          | Float (2) | <p>Check and adjust float drop as follows:</p> <p>a. Hold throttle body (4) in normal installed position so float (2) is facing down.</p> <p>b. Using a short ruler or scale, measure the distance between gasket (5) and two tips of float (2).</p> <p>c. If distance is not 3/8 in. (9.53 mm) minimum, adjust float drop by bending float tab (6) until correct distance is obtained.</p> | <p>Make sure end of scale is placed on part of gasket (5) backed by metal to avoid false reading. Correct distance is 3/8 in. (9.53 mm) minimum.</p> |

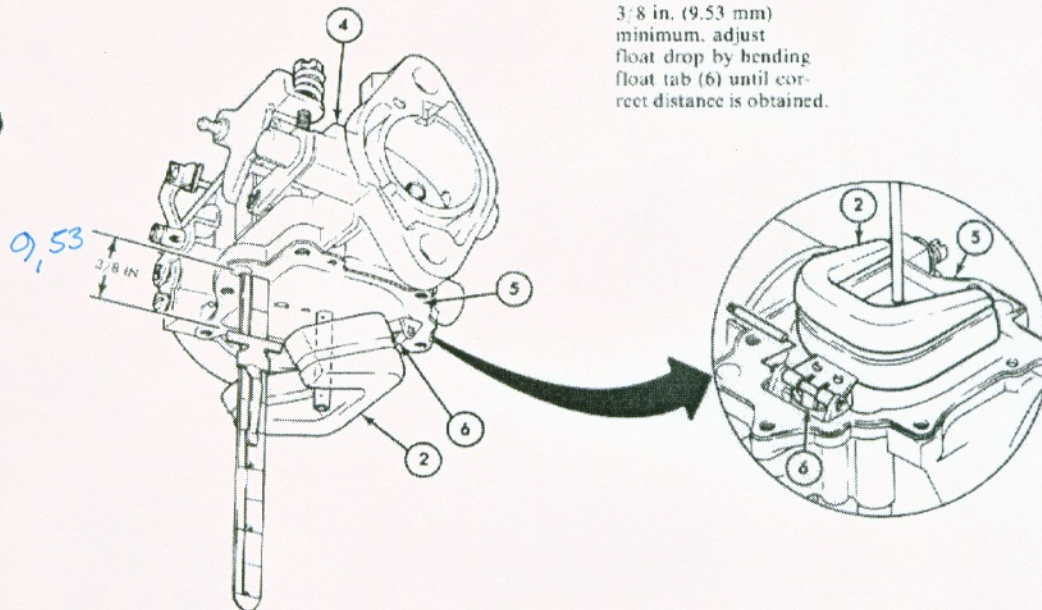

END OF TASK!

FOLLOW-ON TASKS:

- Install carburetor on vehicle (TM 9-2320-218-20-1).
- Adjust fuel mixture (TM 9-2320-218-20-1)

TA 156137

FAX 5614 8980  
Kaj Larsen

TM 9-2320-218-34-1

Justering af karburator  
til Jeep. M151 A1  
Zenith

4-7. Carburetor Overhaul (Cont'd)

| STEP NO. | LOCATION | ITEM | ACTION | REMARKS |
|----------|----------|------|--------|---------|
|----------|----------|------|--------|---------|

d. FLOAT CHECKS AND ADJUSTMENTS

- |     |           |  |  |  |
|-----|-----------|--|--|--|
| 56. | Float (2) | Check and adjust float level as follows:   |  |  |
|     |           | a. Invert throttle body (4) so float (2) is uppermost.   |  |  |
|     |           | b. Using a short ruler or scale (3), measure the distance between gasket (5) and two tips of float (2).<br>Correct distance is $9/32 \pm 1/32$ in. (7.14 ± 0.79 mm).                     | Make sure end of scale is placed on part of gasket (5) backed by metal to avoid false reading. |  |
|     |           | c. If distance is not $9/32 \pm 1/32$ in. (7.14 ± 0.79 mm), adjust float level by bending float arm (1) directly behind buoyant portion of float (2) until correct distance is obtained. | Use needle-nosed pliers.   |  |

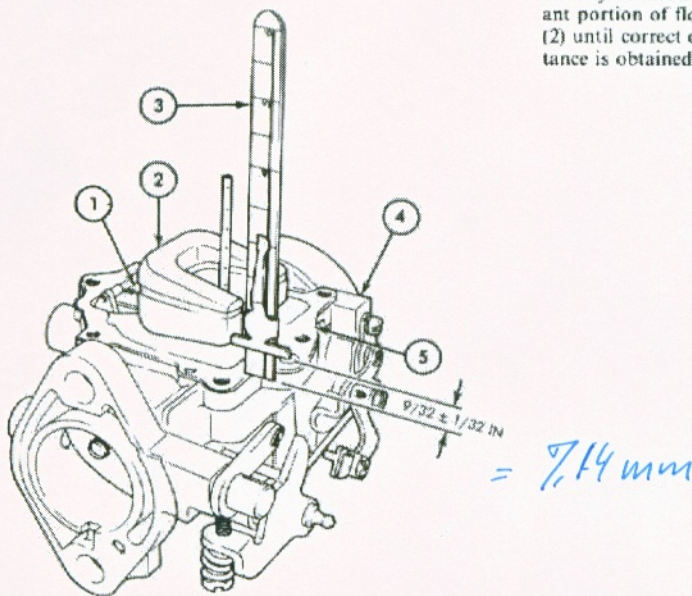

TA 156136

4-18

Hvis du ikke kan forstå det  
engelske, så ring til mig.

gearkasse olie må ikke  
være EP og ikke med  
additiver.

mvh.

Christina

2063 9191